



NEW: RM16 I / IS HS
inrush current up to
350A

DALI-2 RM8/16

Datasheet DT7 Relay Module

Relay Module for the integration of
non-dimmable ballasts
in DALI lighting systems (DT7)

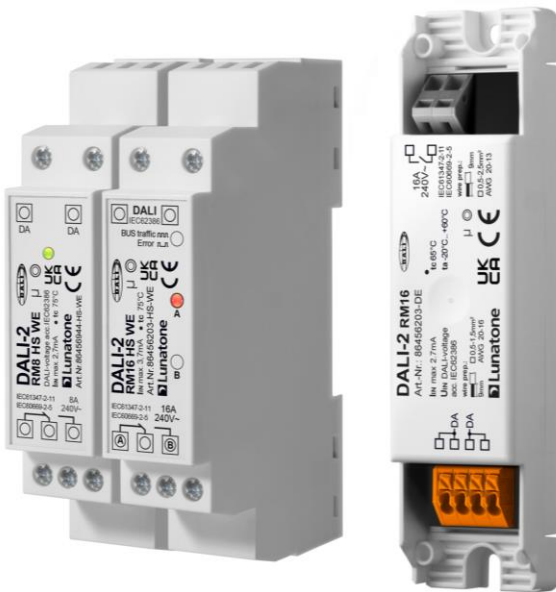

Rail mounting

RM8 HS Art.Nr. 86456944-HS

RM16 HS Art.Nr. 86456203-HS

NEW! RM16 I HS Art.Nr. 86456203-I-HS

NEW! RM16 IS HS Art.Nr. 86456203-IS-HS

RM8 HS WE Art.Nr. 86456944-HS-WE

RM16 HS WE Art.Nr. 86456203-HS-WE

Remote ceiling

RM16 DE Art.Nr. 86456203-DE

Back box

RM8 Art.Nr. 86456944

RM16 Art. Nr. 86456203



DALI-2 RM 8/16 DT7 Relay Module

Overview

- Compact relay module for the direct control of 230V AC loads via DALI
- Ballasts without DALI-input can be simply integrated in a DALI lighting control system. The loads can then be switched ON and OFF by DALI commands.
- The DALI-2 RM8/16 module fulfils the requirements for DALI Device Type 7 - switching function (firmware 2.0 and higher)
- Configurable Power-Up and System-Failure behaviour
- Easy configuration via Lunatone DALI USB interface and DALI-Cockpit Software Tool (suitable interface modules: [DALI-2 USB](#); [DALI USB](#), [DALI-2 WLAN](#), [DALI-2 Display](#), [DALI-2 IoT](#), [DALI 4Net](#), [DALI SCI RS232](#)). The RM8 is supplied directly by the DALI signal line
- The DALI-2 RM 8/16 is supplied directly by the DALI signal line, no additional power supply necessary
- Zero cross switching
- RM16-HS (86456203-HS) and RM16-DE (86456203-DE): integrated current limiter, suitable for loads with high inrush current (>100A)
- RM16-I-HS and RM16-IS-HS: inrush currents up to 350A
- RM16-I-HS and RM16-IS-HS: Standby Feature
- RM16 IS HS: lever on device to manually control relay.
- Time switch functionality
- The modules act like any conventional DALI ballast, and can be addressed and configured accordingly.



Specification, Characteristics

DIN Rail models

type	DALI-2 RM8 HS	DALI-2 RM16 HS	DALI-2 RM16 I HS	DALI-2 RM8 HS WE	DALI-2 RM16 HS WE
article number	86456944-HS	86456203-HS	86456203-I-HS 86456203-IS-HS	86456944-HS-WE	86456203-HS-WE

electrical data					
supply	via DALI-line				
typ. current consumption	2.7 mA		4.1 mA	2.7 mA	
relay output switch on/off voltage	250Vac		277 Vac	250Vac	
max. nominal load circuit breaker	1000VA 6A max	2000VA 12A max	3000VA 16A max	1000VA 6A max	2000VA 12A max

type	DALI-2 RM8 HS	DALI-2 RM16 HS	DALI-2 RM16 I HS	DALI-2 RM8 HS WE	DALI-2 RM16 HS WE
article number	86456944-HS	86456203-HS	86456203-I-HS 86456203-IS-HS	86456944-HS- WE	86456203-HS-WE
max. breaking current	8A	16A	20A	8A	16A
max. inrush current	40A	limited to 100A	350A	40A	80A
max. continuous current	8A	8A	16A	8A	8A
switching method	zero cross switching	zero cross switching integrated current limiter	zero cross switching		
type of relay contact	normally open	normally open	normally open	change-over	change-over
switching operations at nominal load, resistive	>10 ⁵	>10 ⁵	>10 ⁵	>10 ⁵	>3x10 ⁴
maximum switching frequency	1Hz				
input	DALI				
number of used DALI addresses	1				

general data

dimensions	98mm x 17.5mm x 56mm
mounting	DIN rail
protection class	II in intended use
protection degree housing	IP40
protection degree terminals	IP20
behaviour at Power Up	programmable: ON/OFF/no Change
behaviour at System failure	programmable: ON/OFF/no Change

environmental conditions

storage and transportation temperature	-20°C ... 75°C
operating ambient temperature	-20°C ... 60°C

terminals

connection type	screw connector
wire size: solid core	0,5 ... 2,5 mm ² (AWG20 ... AWG14)
wire size: fine wired	0,5 ... 2,5 mm ² (AWG20 ...AWG14)
wire size: using wire end ferrule	0,25 ... 1,5 mm ²
stripping length	7 mm / 0,27 inch
tightening/ release of wire	0,5Nm
release of wire	open screw

standards	
DALI	IEC 62386-102 IEC 62386-208
EMC	EN 61547 EN 50015 / IEC CISPR15
safety	EN 61347-2-11 EN 61347-1
markings	DALI-2, CE, UKCA

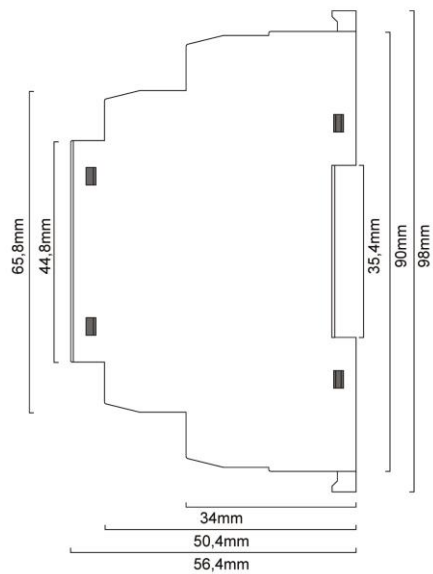

dimensions RM8 HS



17,5mm

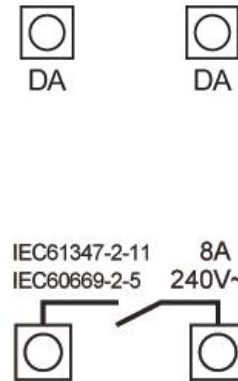

connection plan RM8 HS

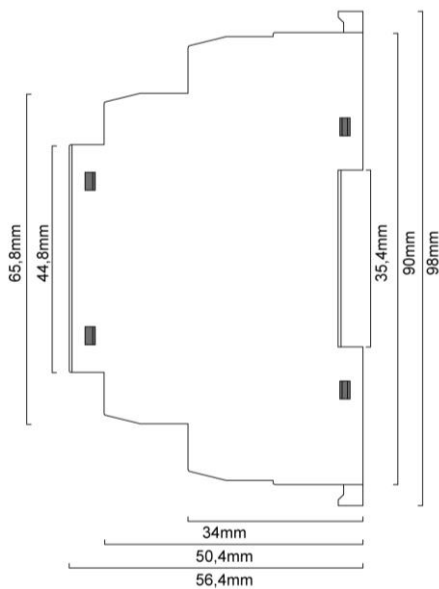

dimensions RM16 HS



17,5mm

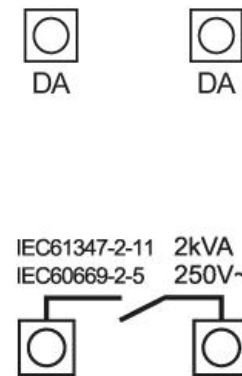

connection plan RM16 HS

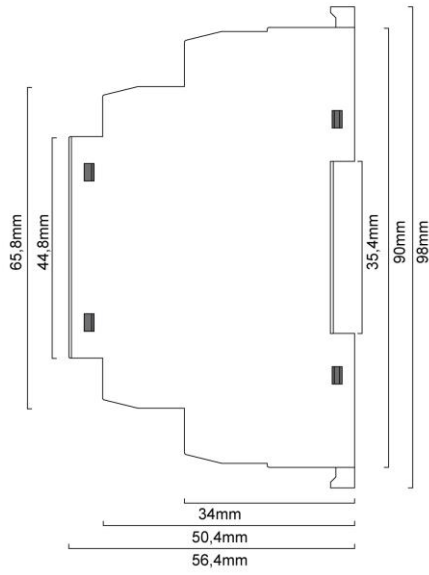

dimensions RM16 I HS

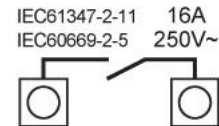

connection plan RM16 I HS

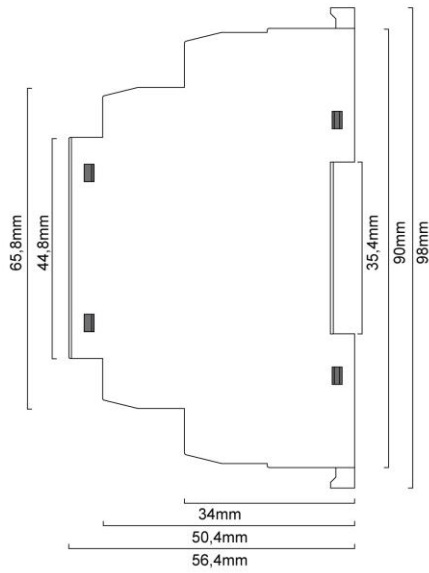

dimensions RM16 IS HS

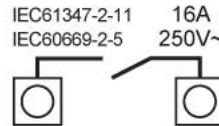

connection plan RM16 IS HS

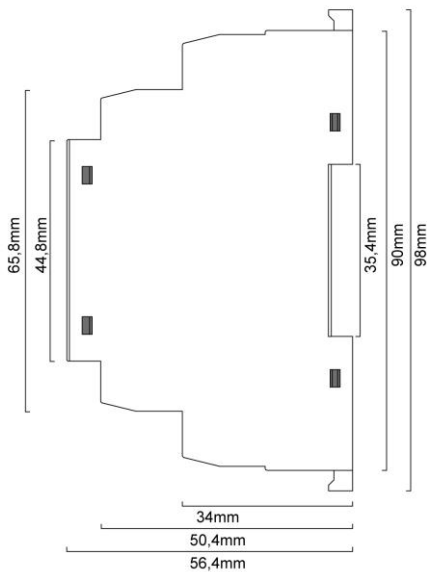

dimensions RM8 HS WE

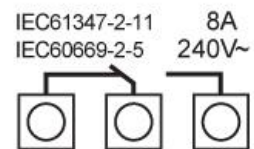

connection plan RM8 HS WE

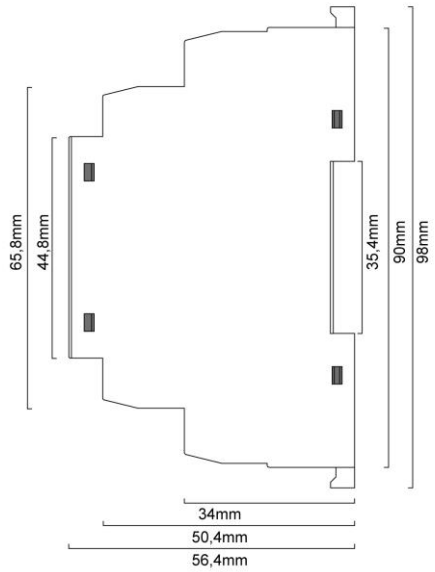

dimensions RM16 HS WE

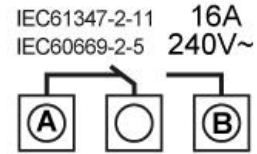

connection plan RM16 HS WE

Remote ceiling models

type	DALI-2 RM16 DE
article number	86456203-DE
electrical data	
supply	via DALI-line
typ. current consumption	2.7 mA
relay output switch on/off voltage	250Vac
max. nominal load circuit breaker	2000VA 12A max
max. breaking current	25A
max. inrush current	internally limited to 100A
max. continuous current	16A
switching method	zero cross switching integrated current limiter
type of relay contact	1 normally open
switching operations at nominal load, resistive	>5x10 ⁴
maximum switching frequency	1Hz
Input	DALI
number of used DALI addresses	1

general data	
dimensions	120mm x 30mm x 22mm
mounting	remote ceiling
protection class	II in intended use
protection degree housing	IP40
protection degree terminals	IP20
behaviour at Power Up	programmable: ON/OFF/no Change
behaviour at System failure	programmable: ON/OFF/no Change

environmental conditions

storage and transportation temperature	-20°C ... 75°C
operating ambient temperature	-20°C ... 60°C

terminals

connection type	spring terminal connectors
wire size: solid core	0,5 ... 1,5 mm ² (AWG20 ... AWG16)
wire size: fine wired	0,5 ... 1,5 mm ² (AWG20 ...AWG16)
wire size: using wire end ferrule	0,25 ... 1 mm ²
stripping length	8,5 ... 9,5 mm / 0,33 ... 0,37 inch
tightening/ release of wire	push mechanism

standards

DALI	IEC 62386-102 IEC 62386-208
EMC	EN 61547 EN 50015 / IEC CISPR15
safety	EN 61347-2-11, EN 61347-1
markings	DALI-2, CE, UKCA

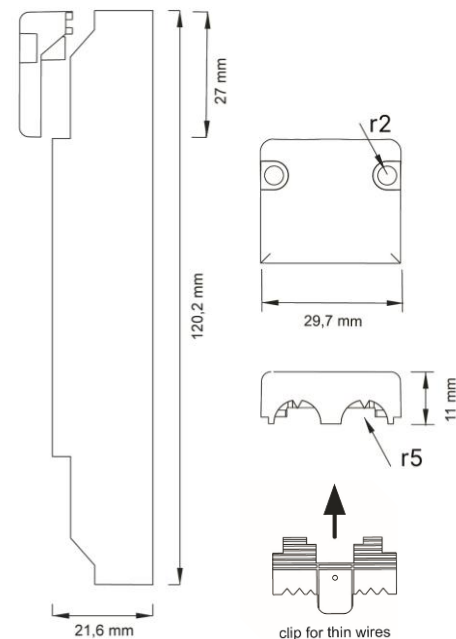

dimensions RM16 DE



connection plan RM16 DE

Installation box models

type	DALI-2 RM16	DALI-2 RM8
article number	86456944	86456203

electrical data:

supply	via DALI-line	
typ. current consumption	2.7 mA	
relay output switch on/off voltage	250Vac	
max. nominal load	1000VA	1000VA
circuit breaker	6A max	6A max
max. breaking current	12A	12A
max. inrush current	60A	60A
max. continuous current	8A	8A
switching method	zero cross switching	
type of relay contact	1 changeover	1 normally open
switching operations at nominal load, resistive	>10 ⁵	>10 ⁵
maximum switching frequency	1Hz	
input	DALI	
number of used DALI addresses	1	

general data

dimensions	59mm x 33mm x 15mm
mounting	installation box
protection class	II in intended use
protection degree housing	IP40
protection degree terminals	IP20
behaviour at Power Up	programmable: ON/OFF/no Change
behaviour at System failure	programmable: ON/OFF/no Change

environmental conditions

storage and transportation temperature	-20°C ... 75°C
operating ambient temperature	-20°C ... 60°C

terminals

connection type	spring terminal connectors
wire size: solid core	0,5 ... 1,5 mm ² (AWG20 ... AWG16)
wire size: fine wired	0,5 ... 1,5 mm ² (AWG20 ...AWG16)
wire size: using wire end ferrule	0,25 ... 1 mm ²
stripping length	8,5 ... 9,5 mm / 0,33 ... 0,37 inch
tightening/ release of wire	push mechanism

standards

DALI	IEC 62386-102 IEC 62386-208
EMC	EN 61547 EN 50015 / IEC CISPR15
safety	EN 61347-2-11 EN 61347-1
markings	DALI-2, CE, UKCA

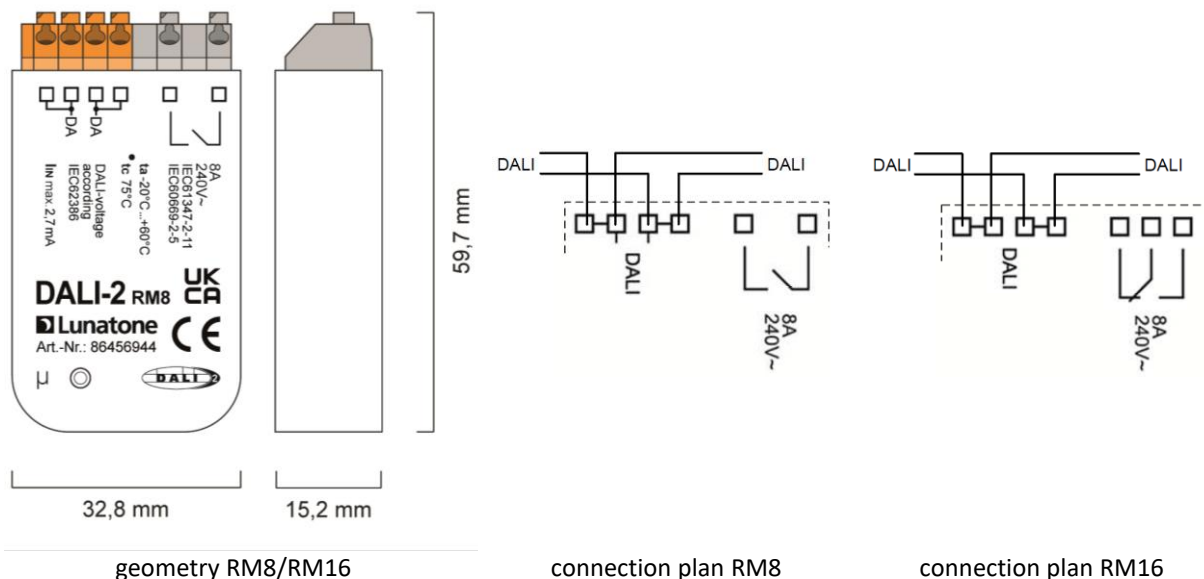

Typical Application

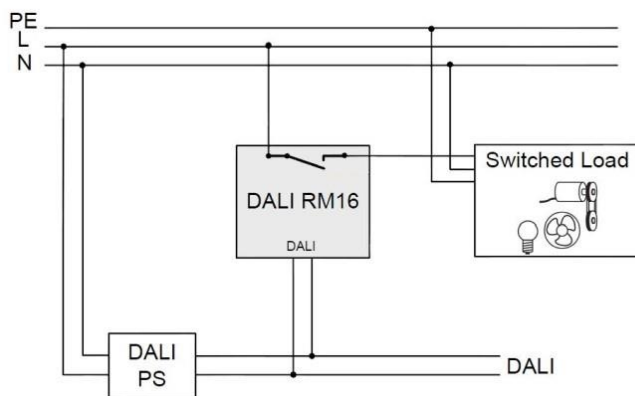

Hint: In order to ensure that the load current does not exceed the maximum switching current, the installation must be secured with a suitable automatic circuit breaker.

Factory Default Settings

A basic configuration is already implemented on delivery (factory default setting). If necessary, this can be changed and adapted.

	Factory default	DALI Standard
Min Level	0.1%	100%
Max Level	100%	100%
Power On Level	MASK (last value)	100%
System Failure Level	MASK (last value)	100%
Fade Time	none	none
Fade Rate	44.7 steps/s	44.7 steps/s
Scene values:	all scenes: MASK	all scenes: MASK
Behaviour at DALI RESET command	set DALI Standard values, see column 2	---
Ignore broadcast commands	disabled	---
Dim UP switch ON threshold	0.1%	--
Dim UP switch OFF threshold	MASK	--
Dim DOWN switch ON threshold	MASK	--
Dim DOWN switch OFF threshold	0%	--

Installation

- The DALI-2 RM8/RM16 is directly connected and supplied by the DALI bus (A typical value of current consumption is 2.7mA). A DALI bus power supply (e.g. [DALI PS](#)) is required, an additional power supply is not necessary.
- The connection to the DALI terminals can be made regardless of polarity. The bus input is protected against overvoltage (mains voltage up to 250VAC).
- The DALI-line must **not** be connected to the mains or extra low voltage systems.
- The device versions for installation-box and remote ceiling have double DALI terminals to allow simple looping through of the DALI bus (which DALI-terminals are internally connected is visualized on the housing, see also the connection plan).
- The relay output of the RM8/16 supports loads up to 2000VA and switching currents up to 16A (type dependent, check specification for details).
- In order to ensure that the load current does not exceed the maximum switching current of the relay a suitable automatic circuit breaker has to be installed.
- Switching is done at zero cross of ac voltage.
- The wiring should be carried out as a permanent installation in a dry and clean environment.
- Installation may only be carried out in a voltage-free state of the system and by qualified specialists.
- National regulations for setting up electrical systems must be followed.
- The DALI wiring can be realised with standard low-voltage installation material. No special cables are required.

- Wiring topology of the DALI-line: Line, Tree, Star
- Only 1 wire may be connected to each terminal. When using double wire end ferrules, the connection capacity of the terminal must be considered.



Attention: The DALI-signal is not classified as SELV circuit (Safety Extra Low Voltage). Therefore, the installation regulations for low voltage apply



The voltage drop on the DALI line must not exceed 2V at maximum length (300m) and maximum bus load (250mA).

Addressing and Configuration

- After installation the DALI-2 RM8/16 is ready for use
- The configuration can be done with the help of the [DALI Cockpit Software](#). The PC must be connected to the DALI bus via a suitable interface module ([DALI-2 USB](#); [DALI USB](#), [DALI-2 WLAN](#), [DALI-2 Display](#), [DALI-2 IoT](#), [DALI 4Net](#), [DALI SCI RS232](#)).
- The DALI-2 RM8/16 is automatically recognised by the DALI Cockpit during the addressing process and listed in the device overview.
- The standard DALI device settings as well as the device specific settings can be configured in the DALI Cockpit, see section "Functionality".
- The "Identify" function can be used for localization after addressing. With the DALI command IDENTIFY, or selecting the checkbox "localise" in the DALI Cockpit the relay switches.

lokalisieren

The IDENTIFY command should not be used if switching of the relay is not desired. Alternatively, the allocation can also be done via the serial number of the device.

Functionality

The DALI RM 8/16 acts as a DALI-controlled relay contact. Hence ballasts can be integrated in a DALI-system and switched on and off by DALI commands.

The DALI-2 RM8/16 acts like a standard DALI ballast for non-dimmable loads. It is based on the DALI specification for control gear (IEC 62386-102) and the device type 7 extension (IEC 62386-208). Therefore, the switching characteristic is determined by the comparison of the virtual direct arc power level (VDAP) with 4 thresholds.

The virtual dim level (VDAP) is like the dim level of DALI-ballasts and is therefore limited by MINLEVEL and MAXLEVEL and influenced by fade-time and fade-rate.

For each dim direction 2 thresholds can be defined. They are compared with the virtual dim level and as a result the output is switched on or off:

virtual dim direction	comparison of virtual dim level and thresholds	output
UP	$VDAP \geq$ UP SwitchOn Threshold	ON
UP	$VDAP \geq$ UP SwitchOff Threshold	OFF
DOWN	$VDAP \leq$ DOWN SwitchOn Threshold	ON
DOWN	$VDAP \leq$ DOWN SwitchOff Threshold	OFF

If a threshold value is set to "MASK" the threshold is inactive and does not influence the relay output.

Some examples of switching characteristics below:

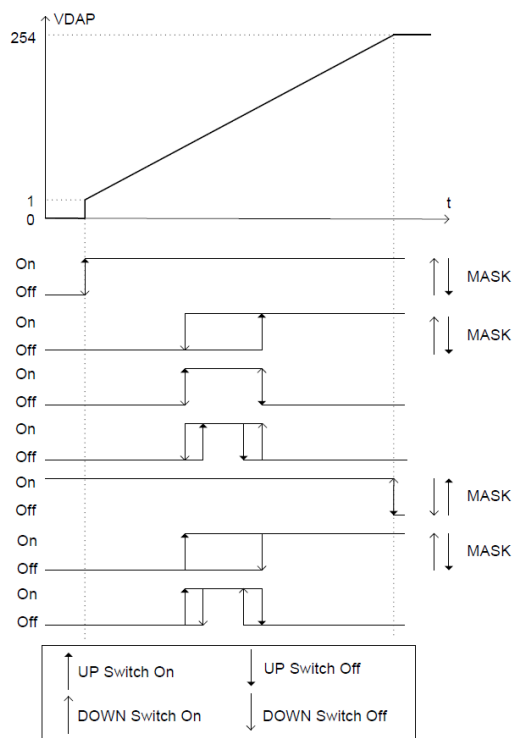

With the help of the fade time switch on and switch off delays can be realized.

Power-ON and System-Failure behaviour

The DALI-2 RM8/16 is bus-powered. The reaction on a system failure can be configured (keep relay state, on or off, factory default: keep state (MASK)). Similarly the Power On level can be configured which is applied in case of switching on the DALI-line supply voltage.

Adjustable RESET behaviour

From FW 4.6. on the response to a DALI reset command is configurable. The following options are available:

- *Ignore command:* the DALI reset command does not trigger any changes to the device settings
- *DALI standard:* the selected device settings are reset to the values defined in

the DALI standard (see table 1 below - second column: DALI standard values)

- *Custom settings:* the current device settings can be saved. With a DALI Reset command, the selected parameters (6 check boxes) are then reset to these saved values.

Ignore Broadcast Commands

The broadcast control can be deactivated. Through selection of “Ignore Broadcast”, the RM8/16 does no longer respond to broadcast commands on the DALI bus (group assignments are not ignored).

Time switch functionality

Timed switching can be activated for four selectable scenes; an immediate action (0%/100%/none) and a delayed action (0%/100%) can be configured. The delay can be selected from 1s-3h.

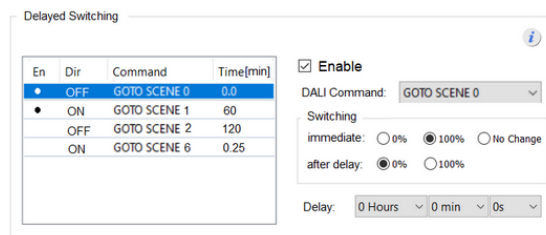

Standby Functionality

Available for DIN rail devices: DALI-2 RM16 I, RM 16 IS.

In order to reduce the standby energy consumption of DALI operating devices, the power supply for these devices can be switched via the DALI-2 RM16.

This “standby functionality” achieves seamless control of the DALI operating devices. “On” commands (Max/Min/Light Level (DAP)/Last Active/Scenes) sent to groups or broadcast switch on the relay (and thus the power supply to the operating devices). To account for the start time of the operating device, the command is sent with several repetitions by the RM16 to the operating devices.

Device Info

Name	DALI-2 RM8	Article Number	86456944	GTIN	9010342014017
Manufacturer	Lunatone	Serial Number	101	FW	0.0
Device Type	7	Type	Control Gear		
DALI Ver	V2.0	Short Address	(A0) DALI-2 RM8		Set

Device Parameters DT7 Settings

Groups

0 1 2 3 4 5 6 7 8 9 10 11 12 13 14 15

DALI Parameter

MIN Level: 100 %

MAX Level: 100 %

Power On Level: MASK %

System Fail Level: 0% 100% No Change

Fade time: ext fade s

Ext Fade Time: fastest

Fade rate: 44.7 step/s

Scenes

0	MASK %	4	MASK %	8	MASK %	12	MASK %
1	MASK %	5	MASK %	9	MASK %	13	MASK %
2	MASK %	6	MASK %	10	MASK %	14	MASK %
3	MASK %	7	MASK %	11	MASK %	15	MASK %

Behavior on DALI Reset Command

Parameters are reset to DALI Standard values.

Ignore Broadcast Config and Arc commands

Ignore Broadcast commands

Figure 1 DALI Cockpit tab: device parameters

Device Info

Name	DALI-2 RM8	Article Number	86456944	GTIN	9010342014017
Manufacturer	Lunatone	Serial Number	101	FW	0.0
Device Type	7	Type	Control Gear		
DALI Ver	V2.0	Short Address	(A0) DALI-2 RM8		Set

Device Parameters DT7 Settings

Thresholds

Up Switch-On Threshold: 0.1 %

Up Switch-Off Threshold: MASK %

Down Switch-On Threshold: MASK %

Down Switch-Off Threshold: 0 %

No dimensions

Switch-On delay: 0.0s On hold time: -s

Switch-Off delay: 0.0s Off hold time: -s

Graph: A graph showing a linear ramp from 0 to 254 over time t[sec]. Below the graph, a blue arrow indicates 'on' and a red arrow indicates 'off'.

Figure 2 DALI Cockpit tab: DT7 settings

Purchase Information

DIN rail:

Art.Nr. 86456944-HS: DALI-2 RM8 HS, 1000VA/8A, zero cross switching, 1 normal open, DIN rail mounting

Art.Nr. 86456203-HS: DALI-2 RM16 HS, 2000VA/16A, zero cross switching, integrated current limiter, 1 normal open, DIN rail mounting

Art.Nr. 86456203-I-HS: DALI-2 RM16 I HS, 3000VA/16A, zero cross switching, integrated current limiter, 1 normal open, DALI-2 certified, DIN rail mounting

Art.Nr. 86456203-IS-HS: DALI-2 RM16 IS HS, 3000VA/16A, zero cross switching, integrated current limiter, 1 normal open, lever on device, DIN rail mounting

Art.Nr. 86456944-HS-WE: DALI-2 RM8 HS WE, 1000VA/8A, zero cross switching, 1 changeover, DIN rail mounting

Art.Nr. 86456203-HS-WE: DALI-2 RM16 HS WE, 2000VA/8A, zero cross switching, 1 changeover, DIN rail mounting

Remote ceiling:

Art. Nr. 86456203-DE: DALI-2 RM16 DE, 2000VA/16A, zero cross switching, integrated current limiter, 1 normal open, remote ceiling

Installation box:

Art. Nr. 86456944: DALI-2 RM8, 1000VA/8A, zero cross switching, 1 normal open, back box

Art. Nr. 86456203: DALI-2 RM16, 1000VA/8A, zero cross switching, 1 changeover, back box

Additional Information and Equipment

DALI-Cockpit – free configuration tool from Lunatone for DALI systems

<https://www.lunatone.com/en/product/dali-cockpit/>

Lunatone DALI products

<https://www.lunatone.com/en>

Lunatone datasheets and manuals

<https://www.lunatone.com/en/downloads-a-z/>

Contact

Technical Support: support@lunatone.com

Requests: sales@lunatone.com

www.lunatone.com



Disclaimer

Subject to change. Information provided without guarantee. The datasheet refers to the current delivery.

The compatibility with other devices must be tested in advance to the installation.